

4

3

2

1

REV	DESCRIPTION	ECD #	DFT	CHK	ENG	DATE
-----	-------------	-------	-----	-----	-----	------

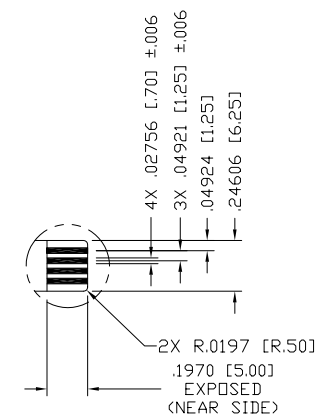
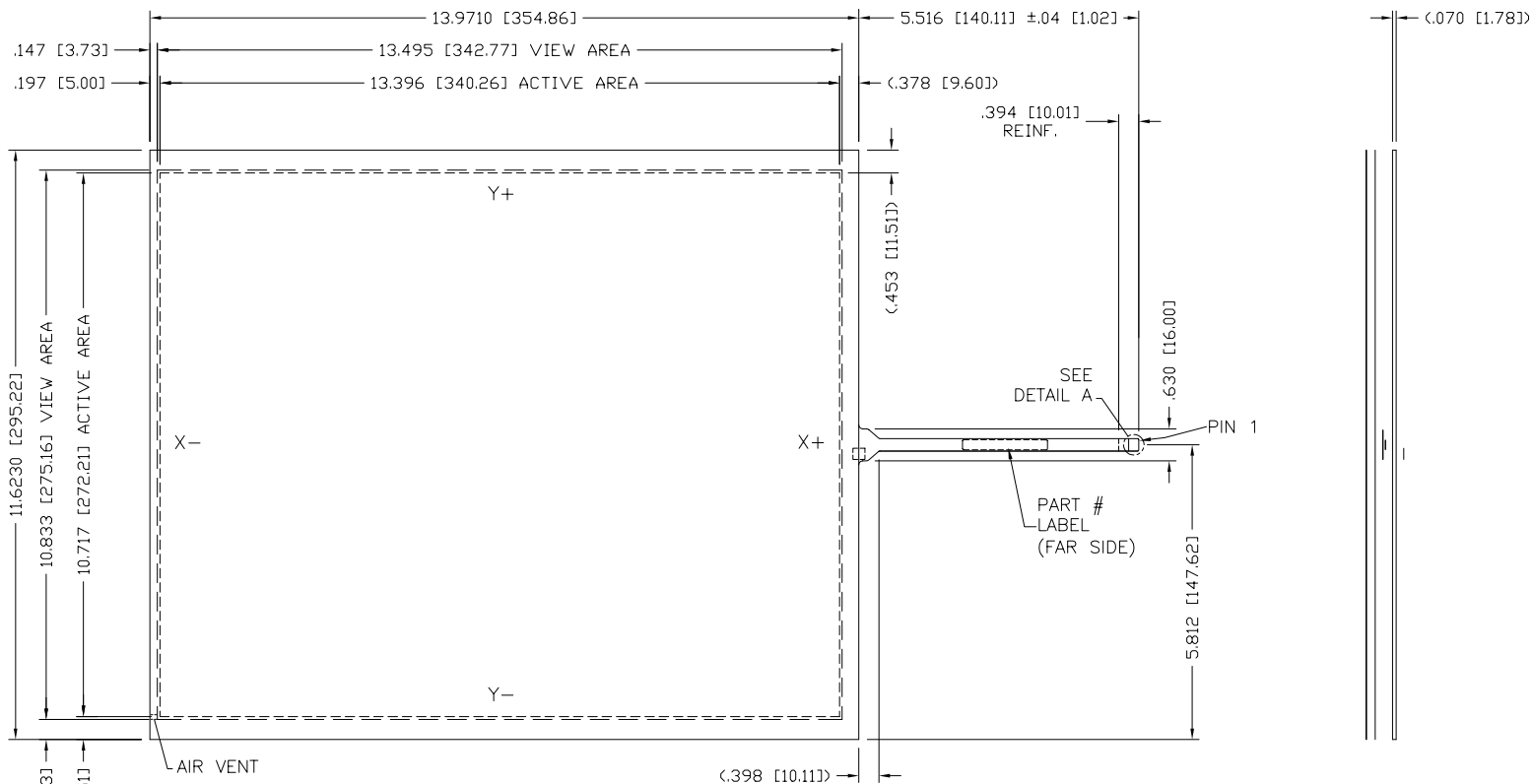

STACK-UP

PINOUT	
PIN	DESCRIP
1	X-
2	Y+
3	X+
4	Y-

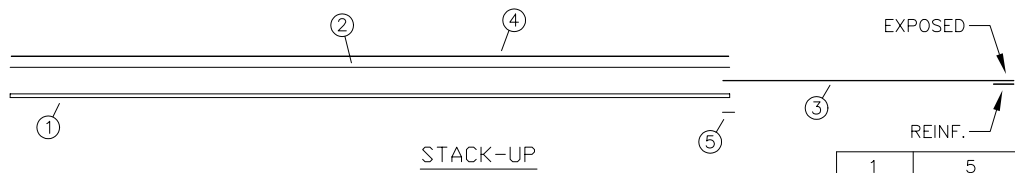

STACK-UP

QTY	ITEM NO	PART NUMBER	DESCRIPTION
1	5		TAIL STRAIN RELIEF
1	4		TOPSHEET SUBASSY (AG)
1	3		TAIL SUBASSY .012 [0.3] THK @ EXPOSED
1	2		GASKET SUBASSY
1	1		BOTTOMSHEET SUBASSY .070 [1.8] THK

FINISHED PART #		NEXT ASSY #	
DO NOT SCALE DRAWING !			
UNLESS OTHERWISE SPECIFIED, DIMENSIONS ARE IN INCHES. REMOVE ALL BURRS AND BREAK SHARP EDGES.			
DEC. TOLERANCE:			
.XX = ±.060 UNO	FRAC. TOL. X/X = ±1/16		
.XXX = ±.020 UNO	ANGULAR TOL. = ±1°		
.XXXX = ±.012 UNO			
.XXXXX = ±.008 UNO			
NOTICE OF PROPRIETARY RIGHTS			TOUCH INTERNATIONAL 2222 West Rundberg Ln #100 Austin, Texas 78758 512-832-8292
THIS DOCUMENT, AND THE INFORMATION IT CONTAINS, IS PROPRIETARY TO TOUCH INTERNATIONAL. IT MUST NOT BE DUPLICATED, OR ITS CONTENTS USED OR DISCLOSED (IN WHOLE OR IN PART) WITHOUT WRITTEN PERMISSION FROM TOUCH INTERNATIONAL.			
DRAWN DATE JH 5/04		TITLE: SENSOR RES 4W 17.1 DIAG	
SCALE: NTS	SIZE	DWG. NO.	REV.
SHEET 1 OF 1	A	48-F-4-171-001	2.1

- NOTES:
- TOPSHEET FINISH: ANTI-GLARE
 - SPACER DOTS: .006 [.15] X .160 [4.06] SPACING, PEN/FINGER INPUT (NOT SHOWN)
 - TOTAL THICKNESS: .083 [2.1] ±.006 [.15]
 - FLEXTAIL: DO NOT BEND TO LESS THAN 1/8" RADIUS
 - MATING CONNECTOR: 1.25MM PITCH ZIF

4

3

2

1

ACAD