

REV	DESCRIPTION	ECD #	DFT	CHK	ENG	DATE
-----	-------------	-------	-----	-----	-----	------

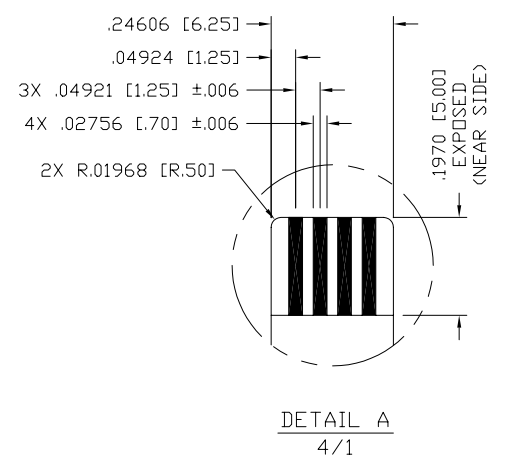

PINOUT	
PIN	DESCRIP
1	X-
2	Y+
3	X+
4	Y-

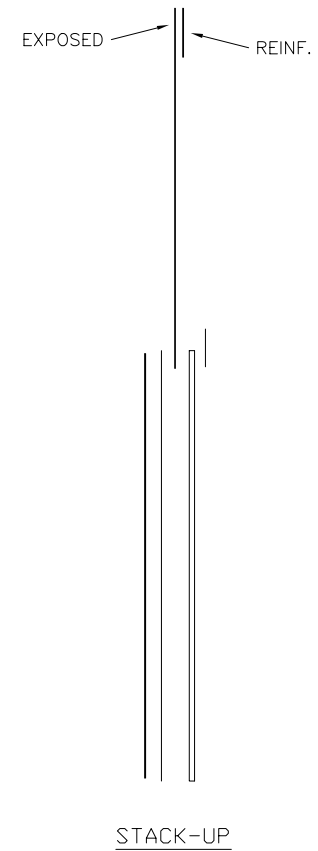
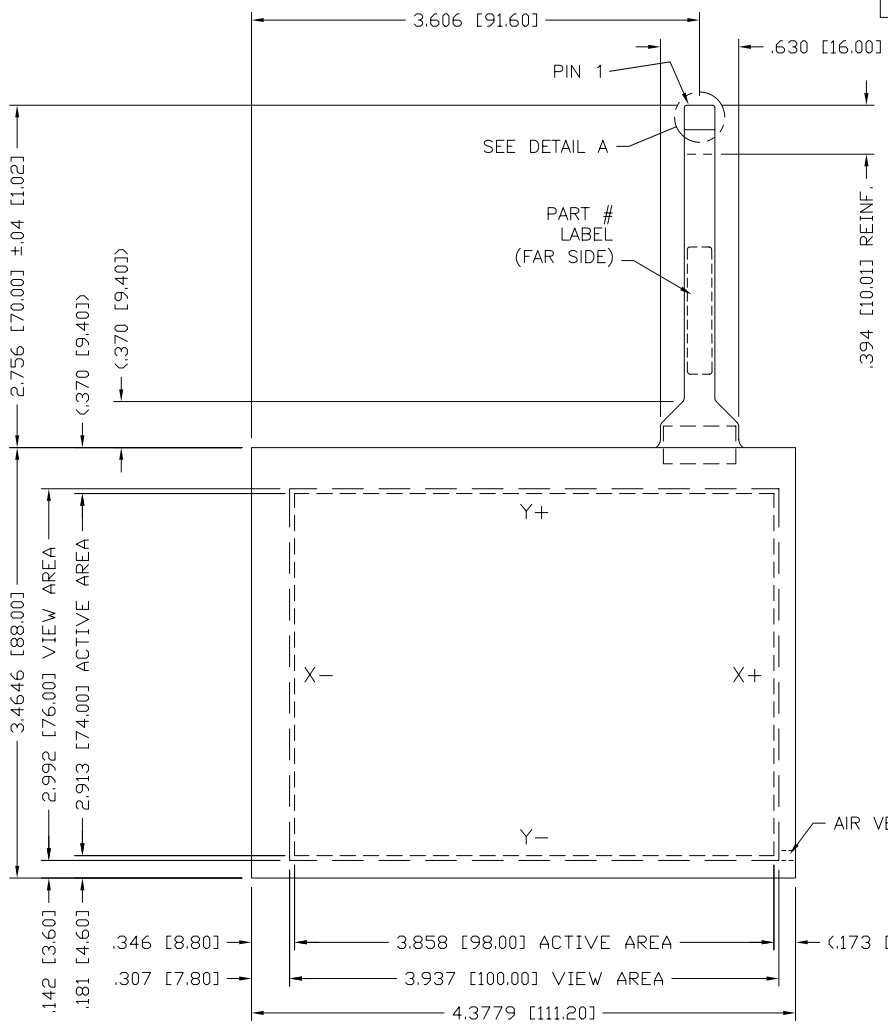
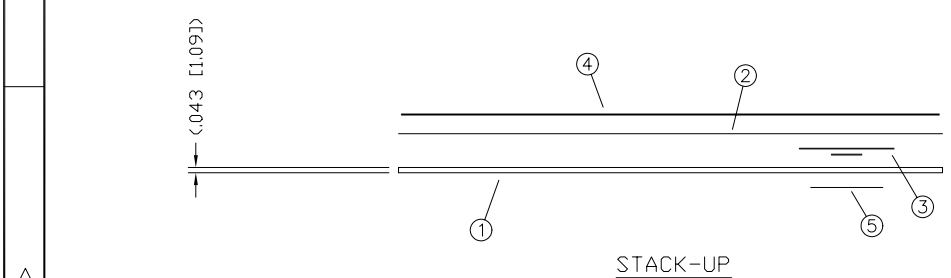

- NOTES:
1. TOPSHEET FINISH: ANTI-GLARE
 2. SPACER DOTS: .006 [.15] X .160 [4.06] SPACING, PEN/FINGER INPUT (NOT SHOWN)
 3. TOTAL THICKNESS: .055 [1.40] ±.006 [.15]
 4. FLEXTAIL: DO NOT BEND TO LESS THAN 1/8" RADIUS
 5. MATING CONNECTOR: 1.25MM PITCH ZIF

1	5		TAIL STRAIN RELIEF
1	4		TOPSHEET SUBASSY (AG)
1	3		TAIL SUBASSY .012 [0.3] THK @ EXPOSED
1	2		GASKET SUBASSY
1	1		BOTTOMSHEET SUBASSY .043 [1.1] THK
QTY	ITEM NO	PART NUMBER	DESCRIPTION

FINISHED PART # _____ NEXT ASSY # _____

DO NOT SCALE DRAWING !
 UNLESS OTHERWISE SPECIFIED, DIMENSIONS ARE IN INCHES. REMOVE ALL BURRS AND BREAK SHARP EDGES.
 DEC. TOLERANCE:
 .XX = ±.060 UNO FRAC. TOL. X/X = ±1/16
 .XXX = ±.020 UNO ANGULAR TOL. = ±1°
 .XXXX = ±.012 UNO
 .XXXXX = ±.008 UNO



TOUCH INTERNATIONAL
 2222 West Rundberg Ln #100
 Austin, Texas 78758
 512-832-8292

NOTICE OF PROPRIETARY RIGHTS
 THIS DOCUMENT, AND THE INFORMATION IT CONTAINS, IS PROPRIETARY TO TOUCH INTERNATIONAL. IT MUST NOT BE DUPLICATED, OR ITS CONTENTS USED OR DISCLOSED (IN WHOLE OR IN PART) WITHOUT WRITTEN PERMISSION FROM TOUCH INTERNATIONAL.

TITLE: **SENSOR RES 4W
4.7 DIAG**

DRAWN DATE R. Johnson 5/04	SCALE: NTS	SIZE A	DWG. NO. 48-F-4-47-001	REV. 2.1
-------------------------------	------------	-----------	---------------------------	-------------